

20. Driven Gear Assembly

A: REMOVAL

- 1) Remove the manual transmission assembly from the vehicle. <Ref. to 6MT(TY85)-31, REMOVAL, Manual Transmission Assembly.>
- 2) Prepare the transmission for overhaul. <Ref. to 6MT(TY85)-38, Preparation for Overhaul.>
- 3) Remove the neutral position switch, back-up light switch and harness. <Ref. to 6MT(TY85)-41, REMOVAL, Neutral Position Switch.> <Ref. to 6MT(TY85)-40, REMOVAL, Back-up Light Switch.>
- 4) Remove the extension case. <Ref. to 6MT(TY85)-42, REMOVAL, Extension Case.>
- 5) Remove the transfer driven gear. <Ref. to 6MT(TY85)-54, REMOVAL, Transfer Driven Gear.>
- 6) Remove the center differential. <Ref. to 6MT(TY85)-56, REMOVAL, Center Differential.>
- 7) Remove the transmission case. <Ref. to 6MT(TY85)-57, REMOVAL, Transmission Case.>
- 8) Remove the driven gear assembly. <Ref. to 6MT(TY85)-63, REMOVAL, Main Shaft Assembly.>
- 9) Remove the 1st needle bearing.

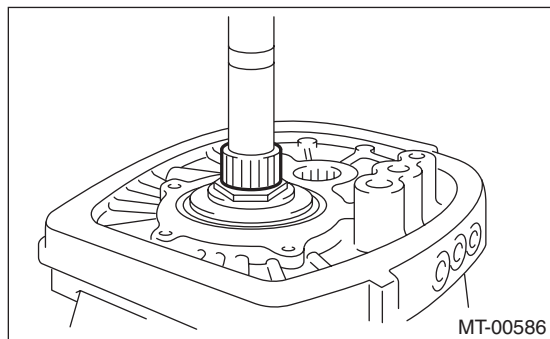

- 10) Remove the thrust needle bearing.

B: INSTALLATION

- 1) Adjust the main shaft snap ring. <Ref. to 6MT(TY85)-75, ADJUSTMENT, Main Shaft Assembly.>
- 2) Adjust the 1st-2nd shifter rod. <Ref. to 6MT(TY85)-110, ADJUSTMENT, Shifter Fork and Rod.>
- 3) Install the thrust needle bearing.

NOTE:

Confirm that the thrust needle bearing is installed in the proper direction.

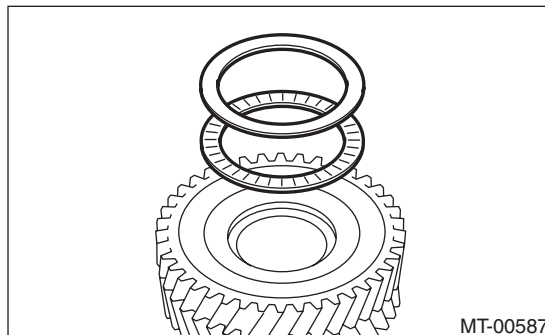

- 4) Install the needle bearing.
- 5) Install the driven gear assembly. <Ref. to 6MT(TY85)-64, INSTALLATION, Main Shaft Assembly.>
- 6) Install the transmission case. <Ref. to 6MT(TY85)-59, INSTALLATION, Transmission Case.>
- 7) Adjust the backlash of the driven gear assembly in the axial direction. <Ref. to 6MT(TY85)-86, ADJUSTMENT, Driven Gear Assembly.>
- 8) Install the center differential. <Ref. to 6MT(TY85)-56, INSTALLATION, Center Differential.>
- 9) Install the transfer driven gear. <Ref. to 6MT(TY85)-54, INSTALLATION, Transfer Driven Gear.>
- 10) Install the extension case. <Ref. to 6MT(TY85)-42, INSTALLATION, Extension Case.>
- 11) Install the neutral position switch, back-up light switch and harness. <Ref. to 6MT(TY85)-41, INSTALLATION, Neutral Position Switch.> <Ref. to 6MT(TY85)-40, INSTALLATION, Back-up Light Switch.>
- 12) Install the manual transmission assembly to the vehicle. <Ref. to 6MT(TY85)-33, INSTALLATION, Manual Transmission Assembly.>

Driven Gear Assembly

MANUAL TRANSMISSION AND DIFFERENTIAL

C: DISASSEMBLY

NOTE:

Individual coupling sleeves and synchronizer hubs meet at a specified position. Before disassembly, mark the meeting position of the coupling sleeve and synchronizer hub.

1) Affix the ST to the work table.

ST 18664AA000 BASE

2) Flatten the tab of the lock nut.

3) Attach ST3 to the lock nut, set the driven gear assembly to the ST, and remove the lock nut.

ST1 18666AA000 HOLDER

ST2 18664AA000 BASE

ST3 18620AA000 ADAPTER WRENCH

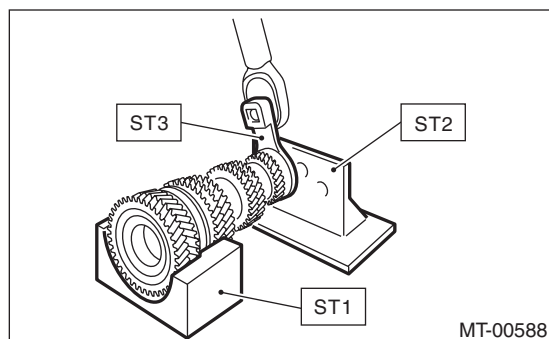

4) Attach ST1 to the 6th driven gear, then remove the ball bearing and 5th-6th driven gear.

ST1 18723AA000 REMOVER

ST2 499877000 RACE 4-5 INSTALLER

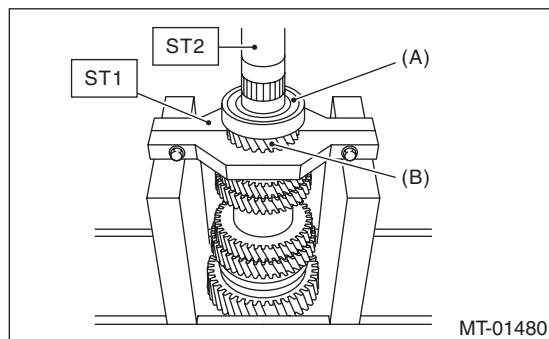

(A) Ball bearing

(B) 5th-6th driven gear

5) Attach ST1 to the 4th driven gear, then remove the 3rd-4th driven gear.

ST1 18723AA000 REMOVER

ST2 499877000 RACE 4-5 INSTALLER

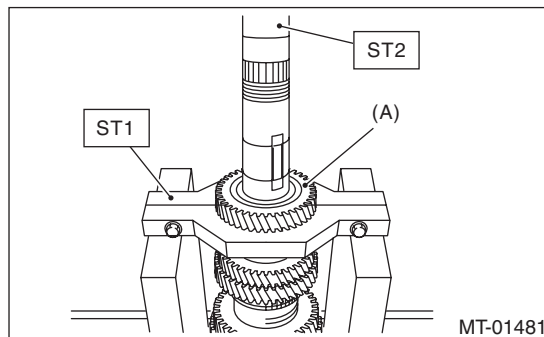

(A) 3rd-4th driven gear

6) Remove the key.

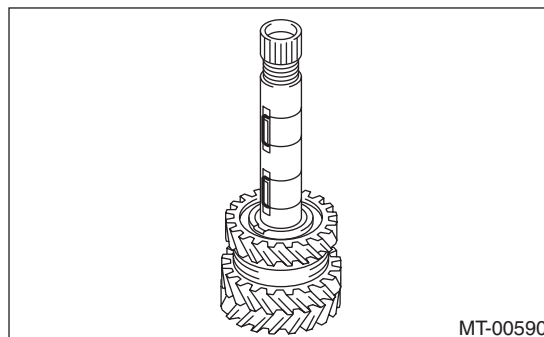

7) Remove the 2nd driven gear.

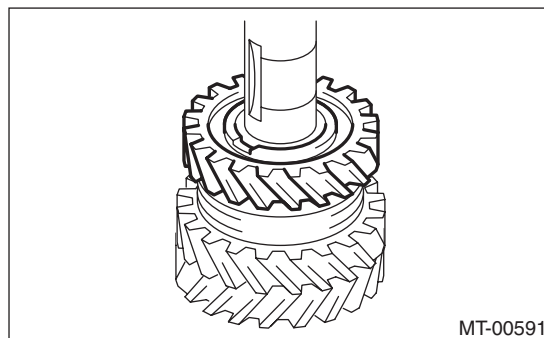

Driven Gear Assembly

8) Remove the needle bearing and 1st-2nd coupling sleeve.

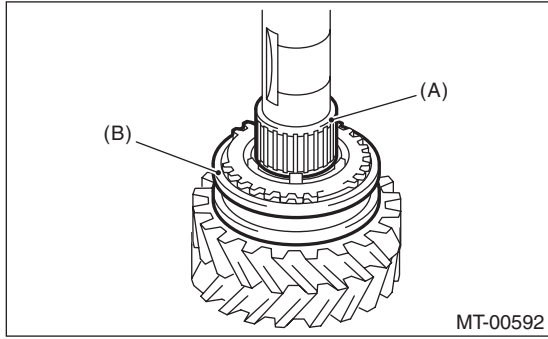

- (A) Needle bearing
- (B) 1st-2nd coupling sleeve

9) Remove the 2nd outer baulk ring, 2nd synchro cone and 2nd inner baulk ring.

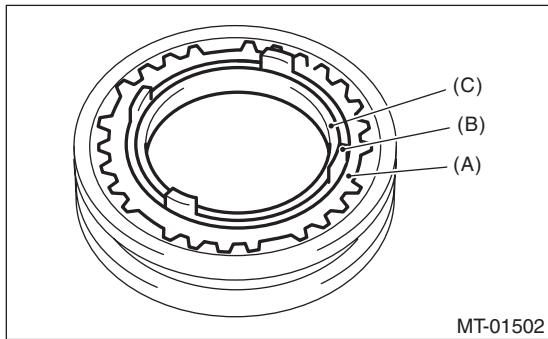

- (A) 2nd outer baulk ring
- (B) 2nd synchro cone
- (C) 2nd inner baulk ring

10) Using the ST, remove individual parts.
ST 18754AA000 REMOVER

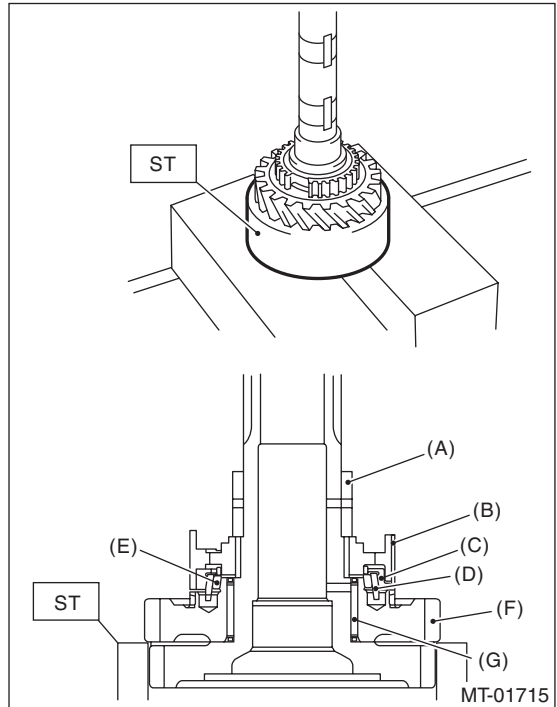

- (A) 2nd drive gear bushing
- (B) 1st-2nd synchronizer hub
- (C) 1st outer baulk ring
- (D) 1st synchro cone
- (E) 1st inner baulk ring
- (F) 1st driven gear
- (G) Needle bearing

Driven Gear Assembly

MANUAL TRANSMISSION AND DIFFERENTIAL

D: ASSEMBLY

NOTE:

When replacing the following parts, replace as a set.

- Coupling sleeve and synchronizer hub
- 1st outer baulk ring, 1st synchro cone and 1st inner baulk ring
- 2nd outer baulk ring, 2nd synchro cone and 2nd inner baulk ring.

1) Apply adequate transmission gear oil to the main shaft, needle bearing and 1st driven gear inner surface.

2) Install the needle bearing.

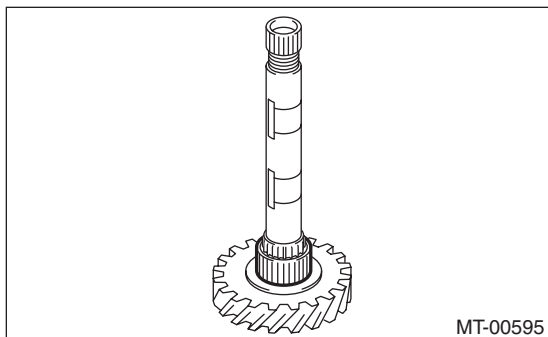

3) Attach the 1st driven gear to the driven shaft.

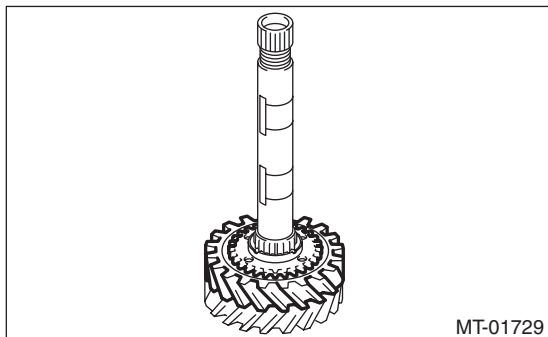

4) Install the 1st inner baulk ring.

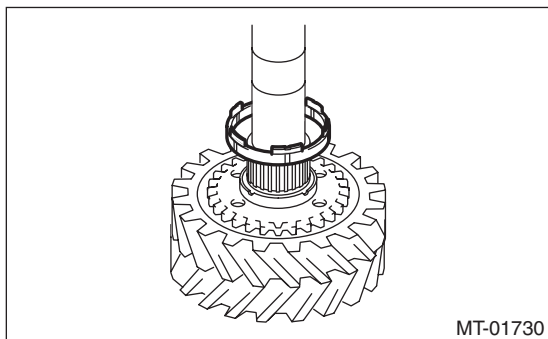

5) Match the protrusion of the 1st synchro cone to the hole of the 1st driven gear, then install.

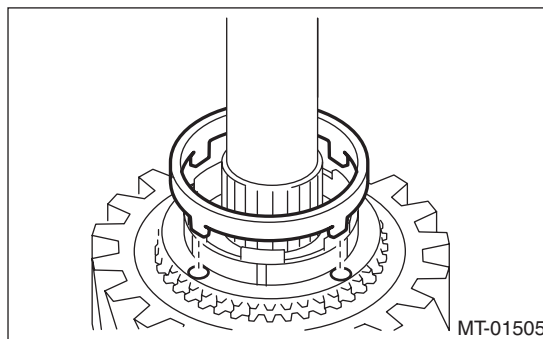

6) Install the 1st outer baulk ring.

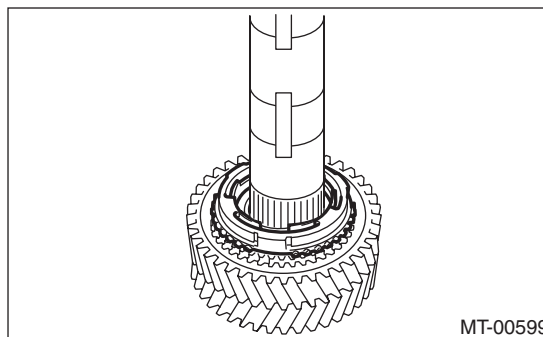

Driven Gear Assembly

7) Install the 1st-2nd synchronizer hub.

CAUTION:

Apply transmission gear oil onto sliding or revolving surfaces before installation.

NOTE:

- Match the cut out of the 1st-2nd synchronizer hub with the protrusion on the outer baulk ring, then install.
- Make sure that the 1st-2nd synchronizer hub is installed in the correct direction.

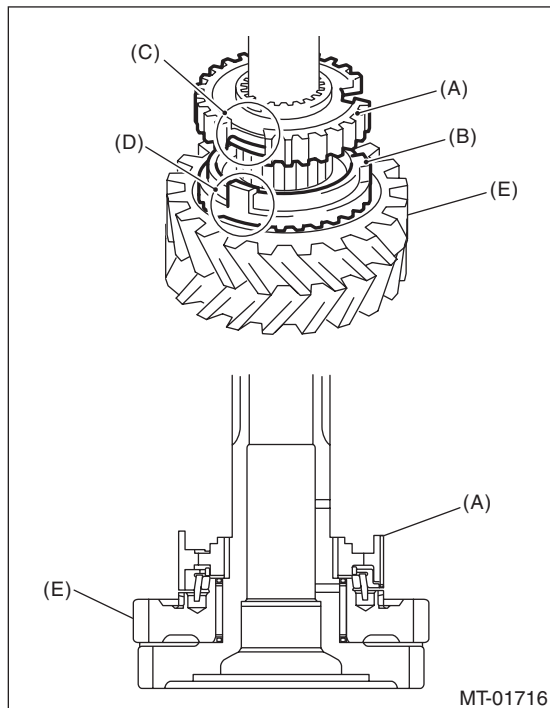

- (A) 1st-2nd synchronizer hub
- (B) 1st outer baulk ring
- (C) Cut out of the 1st-2nd synchronizer hub
- (D) Protrusion of the 1st outer baulk ring
- (E) 1st driven gear

8) Using the ST, install the 1st-2nd synchronizer hub and 2nd driven gear bushing.

ST 18654AA000 INSTALLER

CAUTION:

Do not apply pressure in excess of 40 kN (4.0 ton, 4.4 US ton, 3.9 Imp ton).

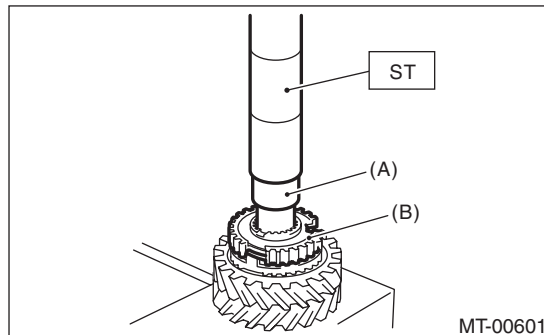

- (A) 2nd driven gear bushing
- (B) 1st-2nd synchronizer hub

9) Make sure that the 1st driven gear can be turned smoothly by hand. If it does not turn smoothly, re-assemble.

Driven Gear Assembly

MANUAL TRANSMISSION AND DIFFERENTIAL

10) Attach the 1st-2nd coupling sleeve to the 1st-2nd synchronizer hub.

NOTE:

- Make sure that the 1st-2nd coupling sleeve is installed in the correct direction.
- Align the 1st-2nd synchronizer hub cut out section (three places) and the key grooves (three places) of shifting insert that are located inside the 1st-2nd coupling sleeve.
- Set the 1st-2nd coupling sleeve and 1st driven gear so that they contact each other.

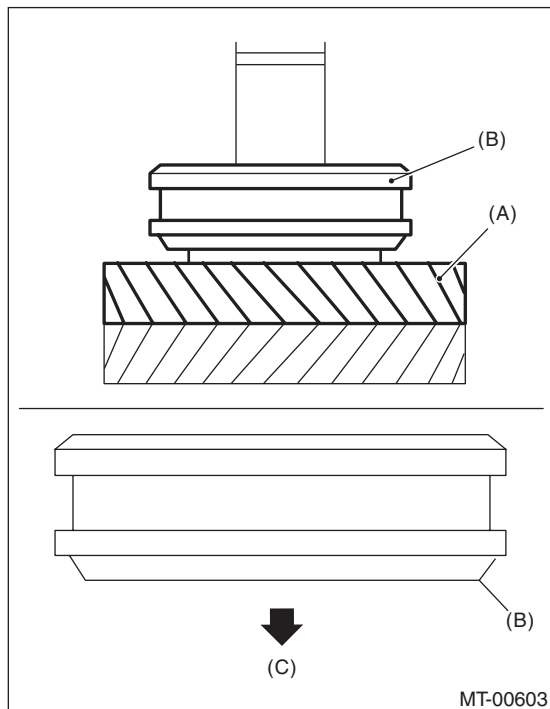

- (A) 1st driven gear
- (B) 1st-2nd coupling sleeve
- (C) 1st driven gear side

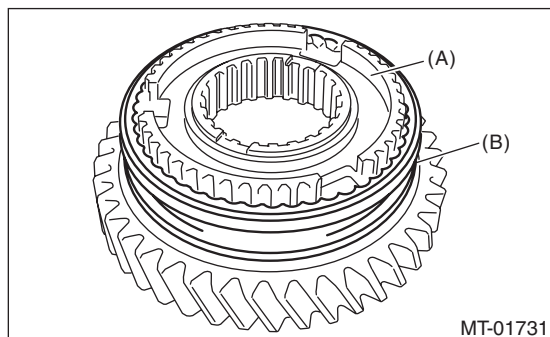

- (A) 1st-2nd synchronizer hub
- (B) 1st-2nd coupling sleeve

11) Attach the shifting insert to the appropriate position of the 1st-2nd coupling sleeve.

NOTE:

- The location angle of each shifting insert is 120°.
- Install the shifting insert to the key grooves (three places) of shifting insert that are located inside the 1st-2nd coupling sleeve.

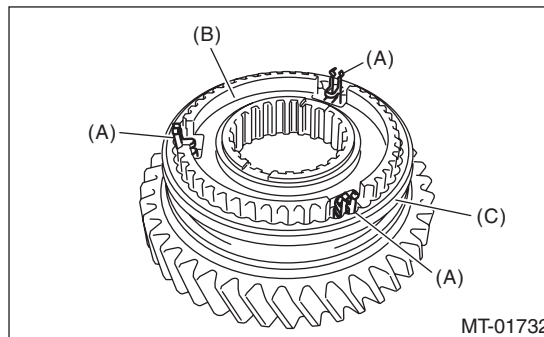

- (A) Shifting insert
- (B) 1st-2nd synchronizer hub
- (C) 1st-2nd coupling sleeve

12) Install the 2nd outer baulk ring.

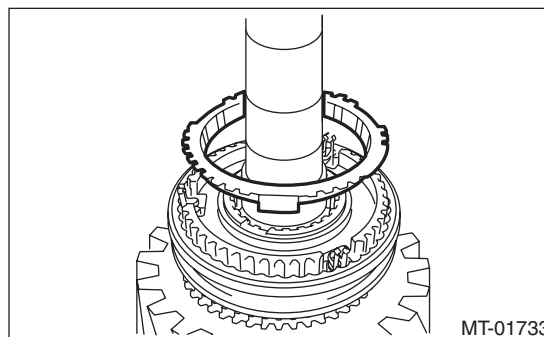

13) Install the 2nd synchro cone.

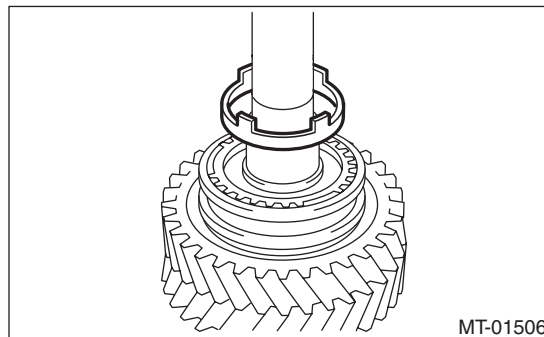

Driven Gear Assembly

14) Install the 2nd inner baulk ring.

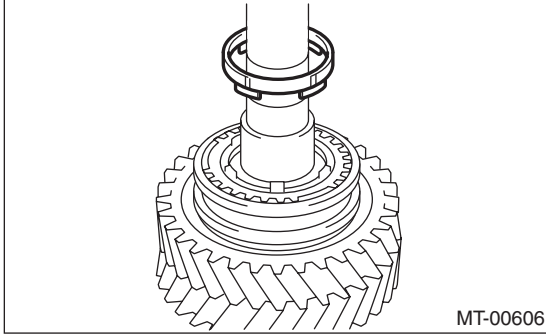

15) Apply adequate transmission gear oil to the 2nd driven gear bushing, needle bearing and 2nd driven gear inner surface.

16) Install the needle bearing and 2nd driven gear.

NOTE:

Match the protrusion of the 2nd synchro cone to the hole of the 2nd driven gear, then install.

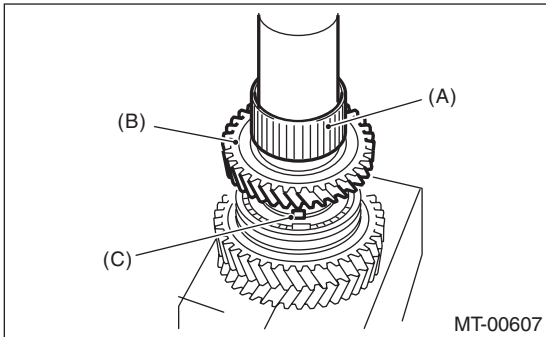

- (A) Needle bearing
- (B) 2nd driven gear
- (C) Protrusion of the 2nd synchro cone

17) Attach the key.

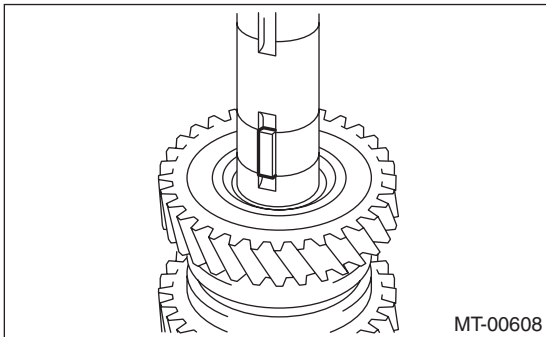

18) Using the ST, install the 3rd-4th driven gear.
ST 18654AA000 INSTALLER

CAUTION:

- Do not apply pressure in excess of 40 kN (4.0 ton, 4.4 US ton, 3.9 Imp ton).
- Apply transmission gear oil onto sliding or revolving surfaces before installation.

NOTE:

- Make sure that the 3rd-4th driven gear is installed in the correct direction.
- Match the groove on the 3rd-4th driven gear to the key.

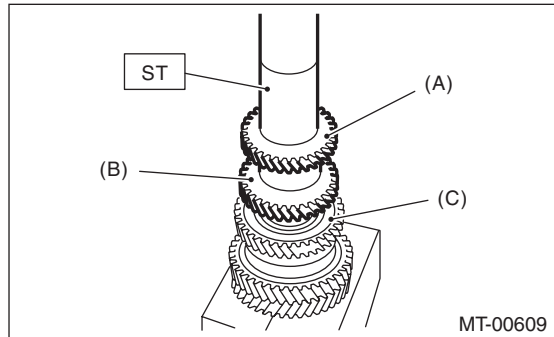

- (A) 4th gear
- (B) 3rd gear
- (C) 2nd gear

19) Make sure that the 2nd driven gear can be turned smoothly by hand. If it does not turn smoothly, reassemble.

20) Attach the key.

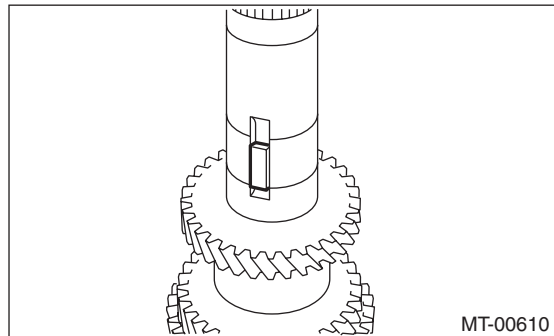

Driven Gear Assembly

MANUAL TRANSMISSION AND DIFFERENTIAL

21) Using the ST, install the 5th-6th driven gear.
ST 18654AA000 INSTALLER

CAUTION:

Do not apply pressure in excess of 40 kN (4.0 ton, 4.4 US ton, 3.9 Imp ton).

NOTE:

- Make sure that the 5th-6th driven gear is installed in the correct direction.
- Match the groove on the 5th-6th driven gear to the key.

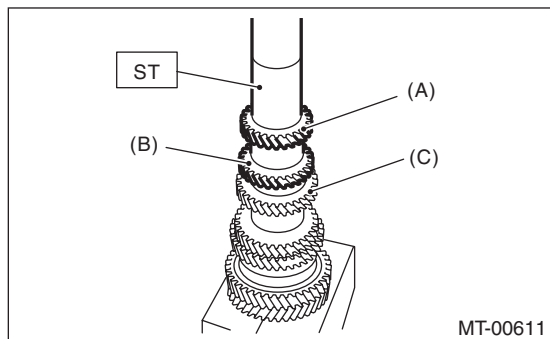

- (A) 6th gear
- (B) 5th gear
- (C) 4th gear

22) Using the ST, install the ball bearing.
ST 18654AA000 INSTALLER

CAUTION:

Do not apply pressure in excess of 40 kN (4.0 ton, 4.4 US ton, 3.9 Imp ton).

NOTE:

Face the sealing section of the ball bearing to the lock nut side, and install the ball bearing.

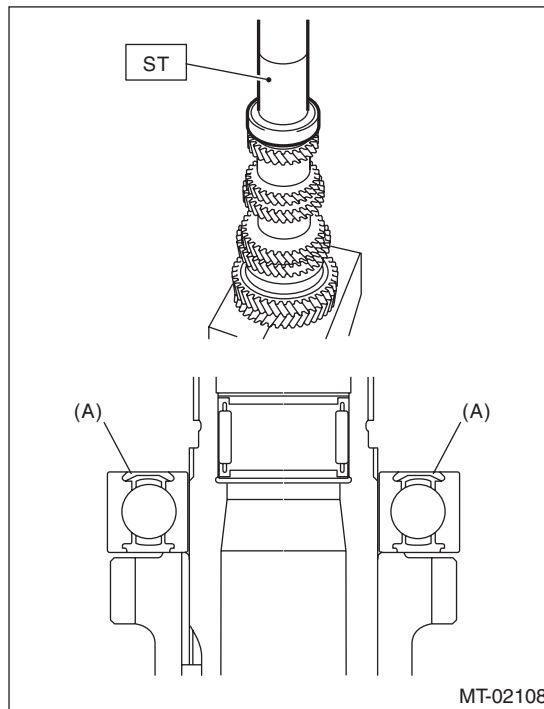

(A) Sealing

23) Make sure that the ball bearing turns smoothly by hand. If it does not turn smoothly, reassemble.
24) Install a new lock nut.

Driven Gear Assembly

25) Attach ST3 to the lock nut, attach ST to the driven gear assembly, and tighten the lock nut.

- ST1 18666AA000 HOLDER
- ST2 18664AA000 BASE
- ST3 18620AA000 ADAPTER WRENCH
- ST4 18852AA000 TORQUE WRENCH

Tightening torque:

530 N·m (54.0 kgf·m, 390.9 ft·lb)

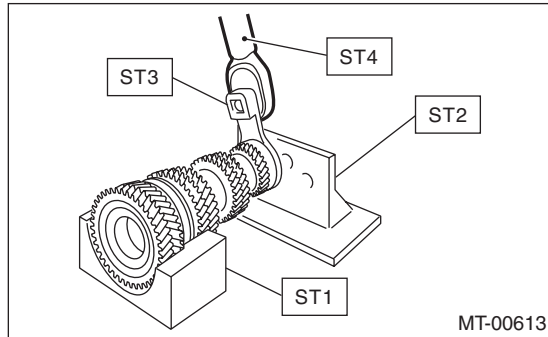

NOTE:

When using a torque wrench other than ST4, use the calculation below to calculate and tighten the lock nut.

$$T = L1 / (0.1 + L1) \times 570$$

T	N·m (kgf·m, ft·lb)	Torque wrench setting
L1	m (in)	Torque wrench length
0.1 m (3.94 in)		Length of ST
570 N·m (58.1 kgf·m, 420 ft·lb)		Tightening torque (lock nut)

26) Using the ST, crimp the lock nut in 4 locations, with dimensions within A 44±0.5 mm (1.73±0.02 in).

- ST 18669AA000 PUNCH DRIVEN SHAFT

NOTE:

Do not damage the crimp area of the lock nut.

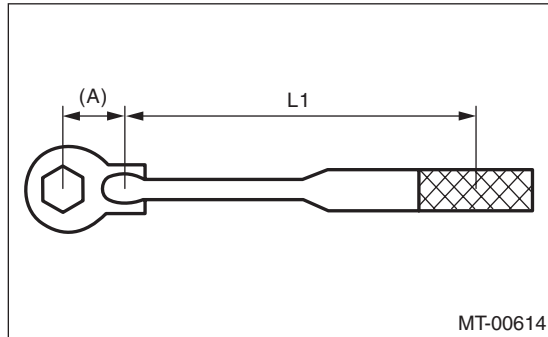
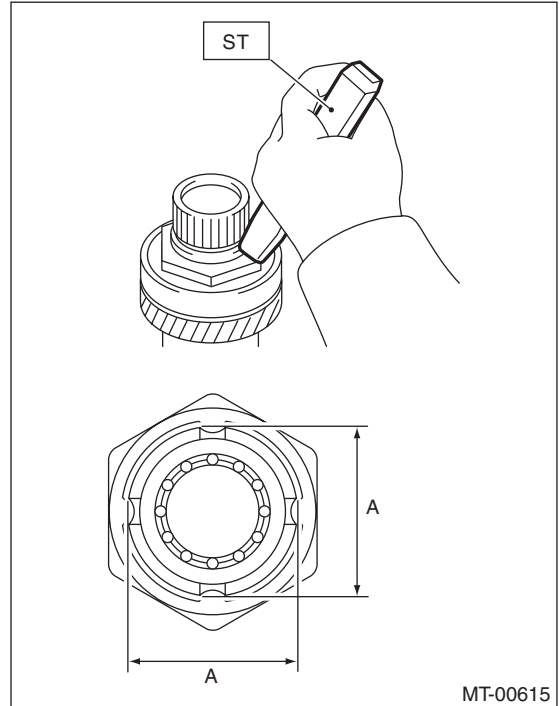

(A) 0.1 m (3.94 in)

Driven Gear Assembly

E: INSPECTION

Disassembled parts should be washed with cleaning solvent first, then inspected carefully.

1) Bearing

Replace the bearings in the following cases.

- Wear, rusting or damage of the bearings
- The bearing does not rotate smoothly or an abnormal noise is emitted when turning.
- The bearing has other defects.

2) Bushing (each gear)

Replace the bushing in following cases.

- The sliding surface is damaged or abnormally worn.

3) Gear

Replace gears in the following cases.

- The gear teeth surface is damaged or excessively worn.
- The contact area of the baulk ring is damaged.
- The inner face of the gear is worn.

4) Baulk ring, synchro cone

Replace the baulk ring and synchro cone in the following cases.

- Wear, rusting or damage of the baulk ring

5) Shifting insert

Replace the shifting insert key if deformed, excessively worn or defective in any way.

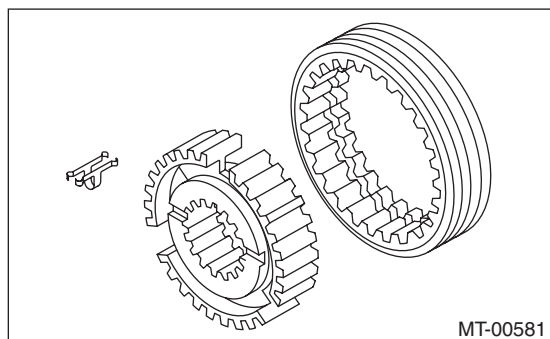

F: ADJUSTMENT

1) Measure the length “H” from the transmission case and transfer bearing holder mating surface, to the end face of the ball bearing.

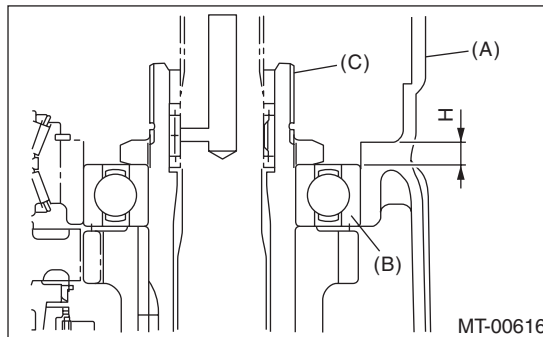

- (A) Transmission case
- (B) Ball bearing
- (C) Driven gear ASSY

2) Using the following calculation, calculate the thickness of the driven gear assembly adjusting washer.

$$T = H - \{5.8 \pm 0.05 \text{ mm (} 0.23 \pm 0.002 \text{ in)}\} - \{0.1 - 0.3 \text{ mm (} 0.0039 - 0.0118 \text{ in)}\}$$

T	Adjusting washer thickness
H	Length from the transmission case and transfer bearing holder mating surface to the end face of the ball bearing
5.8±0.05 mm (0.23±0.002 in)	Collar thickness
0.1 — 0.3 mm (0.0039 — 0.0118 in)	Driven gear assembly axial direction backlash standard

3) Select 0 to 3 adjusting washers from the following table, and adjust to the backlash that is closest to the standard value.

Driven gear assembly axial direction backlash standard:

0.1 — 0.3 mm (0.0039 — 0.0118 in)

Adjusting washer	
Part No.	Thickness T mm (in)
803072030	0.15 (0.0059)
803072031	0.30 (0.0118)
803072032	0.45 (0.0177)
803072033	0.60 (0.0236)